

VP Major S.S



Description

Tank washing is a vital part of a ship's operation and it is essential that the equipment onboard is reliable and fit for purpose. Victor Marine bring with them a long tradition of supplying robust and efficient equipment and can offer both twin and single nozzle machines, offering a solution to all tank washing problems.

The VP Major is a pre-programmed twin nozzle tank washing machine available in 316 Stainless Steel.

This unit is suitable for use on both medium and large crude oil chemical and product tankers and can be supplied as a fixed or portable application.

Typical Installation

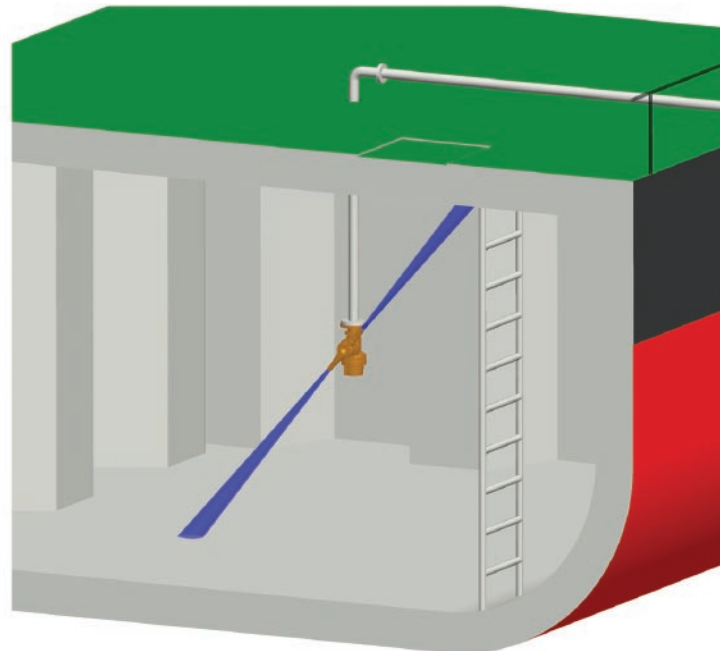

Key Features

- ▶ Uses an orbital progressive intensity wash pattern to meet IMO Annex II pre-wash requirements;
- ▶ Nozzle sizes range from 11mm to 18mm;
- ▶ Offered with either 'sealed for life' or 'media lubricated' drive to ensure no cargo contamination;
- ▶ Complete with automatic 'slip-clutch' to prevent accidental damage in use;
- ▶ Simple to service, with use of 'hi-performance' long life gears;
- ▶ Alternative flange (up to 180mm diameter) and fixings available;
- ▶ Fully Type Approved by Class Societies worldwide.

Please see overleaf or separate 'Ancillaries' information sheet for details.

TECHNICAL SPECIFICATION

Supply Pressure kg/cm ²	NOZZLE DIAMETERS														
	2x11mm			2x12mm			2x14mm			2x16mm			2x18mm		
	Flow m ³ /hr	Jet Length mtrs	Cycle Time mins	Flow m ³ /hr	Jet Length mtrs	Cycle Time mins	Flow m ³ /hr	Jet Length mtrs	Cycle Time mins	Flow m ³ /hr	Jet Length mtrs	Cycle Time mins	Flow m ³ /hr	Jet Length mtrs	Cycle Time mins
8	26	14	37	32	15	39	42	17	43	50	18	42	57	19	49
10	29	16	34	35	17	36	45	19	39	55	20	39	64	21	46
12	33	18	32	40	19	34	51	21	37	61	22	37	70	23	44

General arrangement

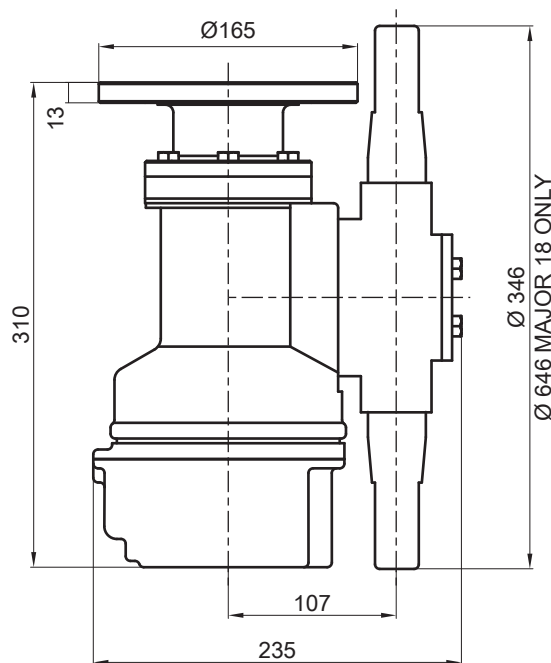

Design Service

Our Engineering Department offers a full design service including product selection and shadow diagrams prior to installation.

Wash Pattern

Pre-programmable Rotary 360°

Jet Length

Maximum: 38mtrs (123ft)
Typical: 20-35mtrs(66-115ft)

Operating Pressure

Maximum: 12 kg/cm² (190 psi)
Optimum: 5-10kg/cm² (72-145 psi)

Flow Capacity

Minimum: 23 m³/hr (101 US gal/min)
Maximum: 65 m³/hr (286 US gal/min)

Wash Cycle

Time: Variable on supply pressure
Typical: Between 34-50 mins
Type: 4 cycles for complete wash

Operating Temperature

Maximum: 95°C (203°F)

Lubrication

via wash media or sealed grease lubricated gearbox

Installation

Min deck opening: Ø 245mm (9.6 inches)
Fixed flanged: Std SIN 50 NP16
(Ø 165mm with 4x18mm holes on a 125 PCD)
Portable: 2½" ANSI Male thread

Weight

Fixed flanged: 21 kgs (46 lbs)
Portable: 19.5 kgs (43 lbs)

Ancillary equipment available

Layflat and Rigid Hoses, Ducting, Various Fittings and Adaptors, Transport Trolley.

Please see separate 'Ancillaries' information sheet for details.